

## Diagnosing Catalytic Converters using the 80T-IR/E Extended Range Infrared Probe

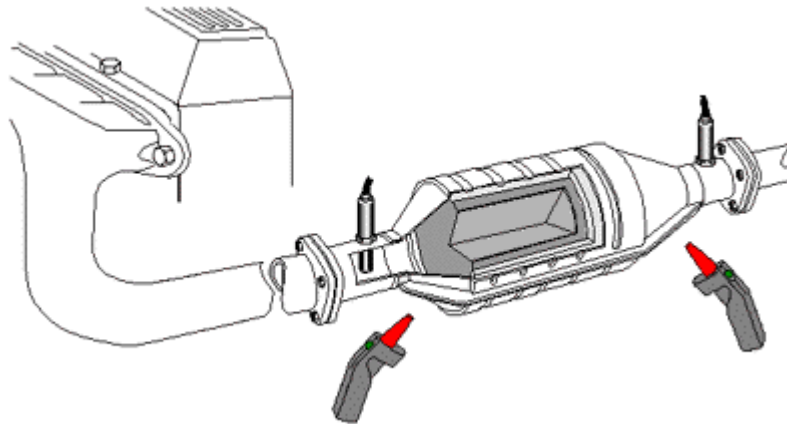

With the 80T-IR/E Extended Range Temperature Probe, you can easily and quickly assess catalytic converter efficiency. For this test, first run the engine until the engine is warm and stabilized. (For engines with electric cooling fans, let them cycle a few times prior to the test) Then shut off the engine and disconnect a spark plug wire on one bank of cylinders. (Note for V engines: If there are dual converters, you will need to perform this procedure on each bank of cylinders.

Restart the engine and block the throttle to maintain 1000 RPM with the one cylinder not firing. Measure the inlet temperature of the converter and compare it to the outlet temperature. You should see a differential of 50 degrees F. or more if the converter is working properly. If the temperatures are less than 50 degrees apart, then the converter needs to be replaced. Before replacing a converter, be sure to determine why it may have failed. If it is a very high mileage vehicle, it is probably just expired. If it is low mileage, you should perform a thorough check of the vehicle to determine the cause.

For normal engines with a misfiring cylinder at 1000 RPM, you can expect that the temperatures observed will be in the 600 to 900 degrees F. range.